

# Vacant to Vibrant - Land Bank (**v2V-Lb**)

Presented by

Jim DeLisle, Ph.D.

Legal Technology Laboratory Conference

November 16, 2017

# v2V-Lb Project Value Proposition

- Land Banks and Abandoned Housing
  - Abandoned Properties are a Significant Component of Urban Blight
  - Land Banks Can Help Reduce Abandoned Housing Problem
- Value-Add Proposition
  - Help Land Bank Achieve Dual Mission
    - Housing Access
    - Economic Development
  - Help buyers make more informed selection decisions
    - Properties Selection
    - Neighborhood Selection
  - Stakeholder Tool
    - Neighborhoods
    - Policy-makers



## v2V-LB Context

- Land Bank Problem
  - Inflow exceeds outflow
  - Resource limitations
- Property Profile
  - Many properties in disrepair
  - Neighborhoods often blighted
- Buyer Constraints
  - Resources
  - Capital
  - Information
  - Risk tolerance
  - Experience

### Total Land Bank

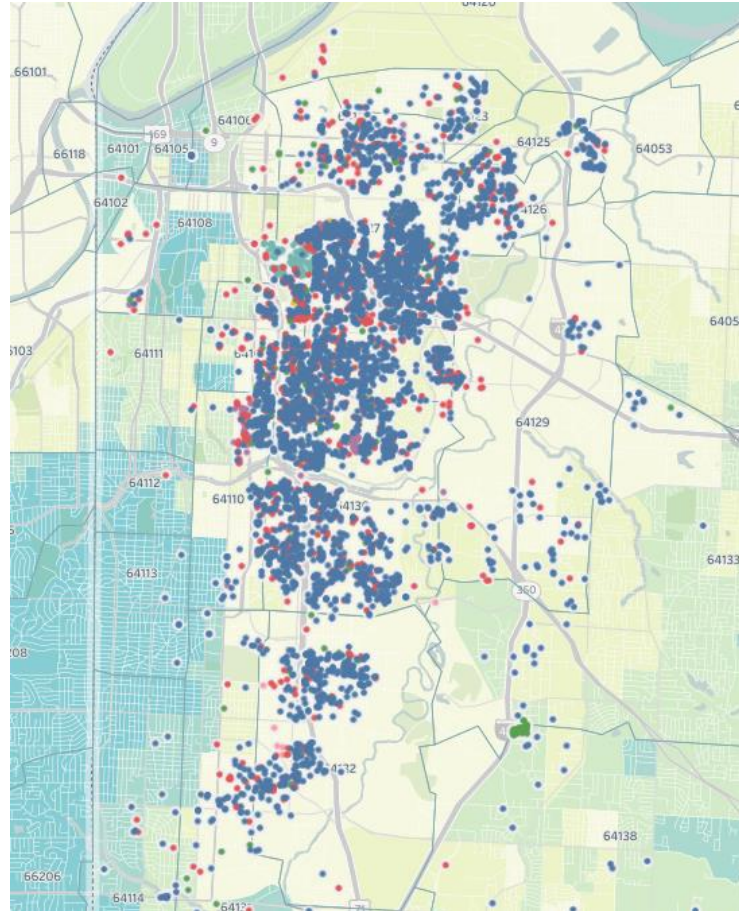

### Sold Land Bank

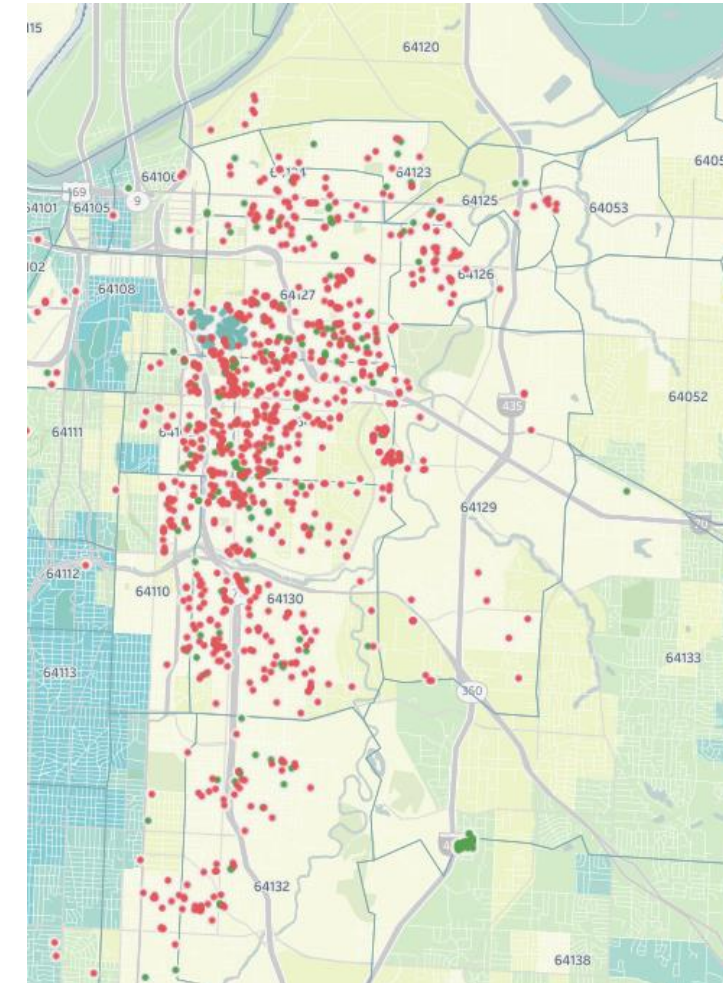

# Residential Improved Land Bank Sales

## Sold Properties

Type of Buyer	Code	Number Sold	Total Value		Average Value	
			Deed of Trust	Sales Price	Deed of Trust	Sales Price
Renovate and Occupy	SR	330	\$8,134,511	\$603,428	\$24,650	\$1,829
Renovate for Others	SRO	252	\$5,575,345	\$299,144	\$22,124	\$1,187
Total		582	\$13,709,856	\$902,572	\$23,387	\$1,508

## Status of Sold Properties

Type of Buyer	Code	Total	Pending	Sold	Withdrawn, Fell Through	Withdrawn Percent
Renovate and Occupy	SR	330	37	234	59	18%
Renovate for Others	SRO	252	19	216	17	7%
Total		582	56	450	72	12%

# Multi-stage Design Process

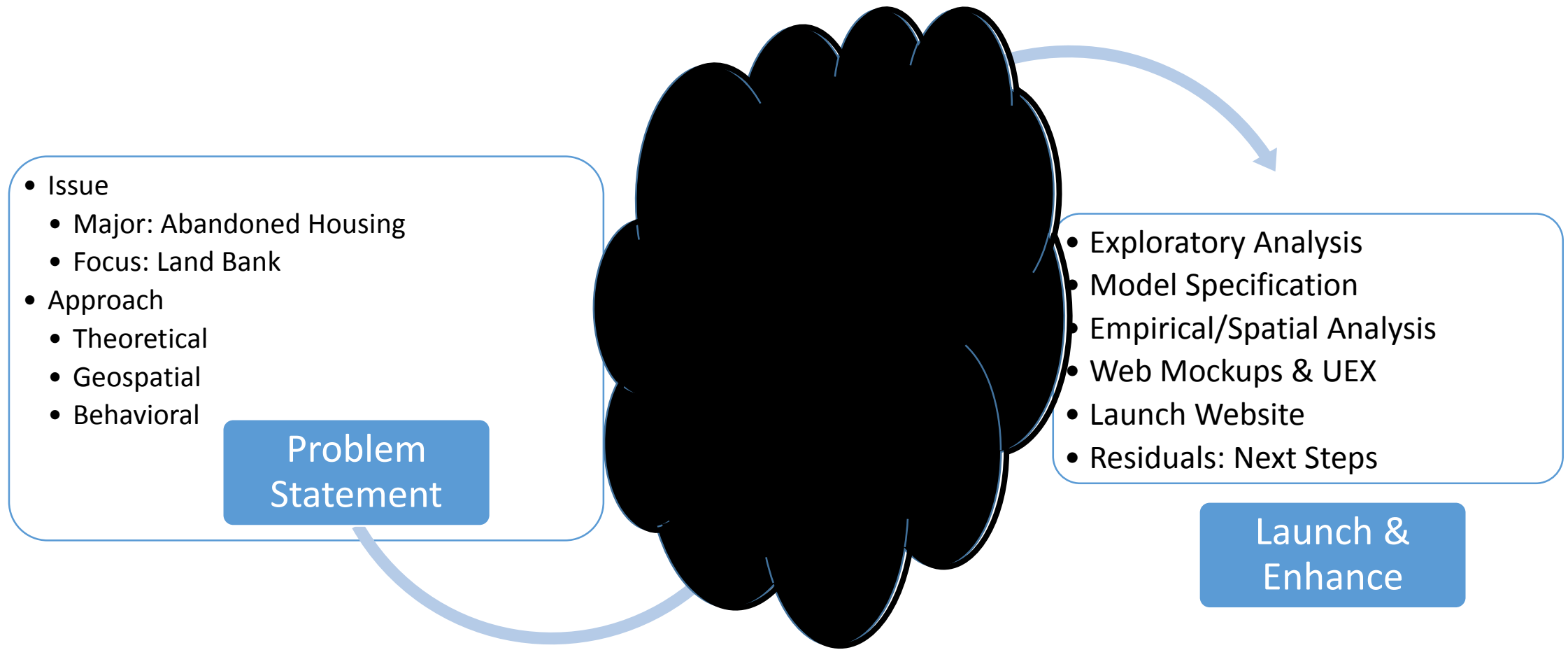

# What, For Whom, By Whom?

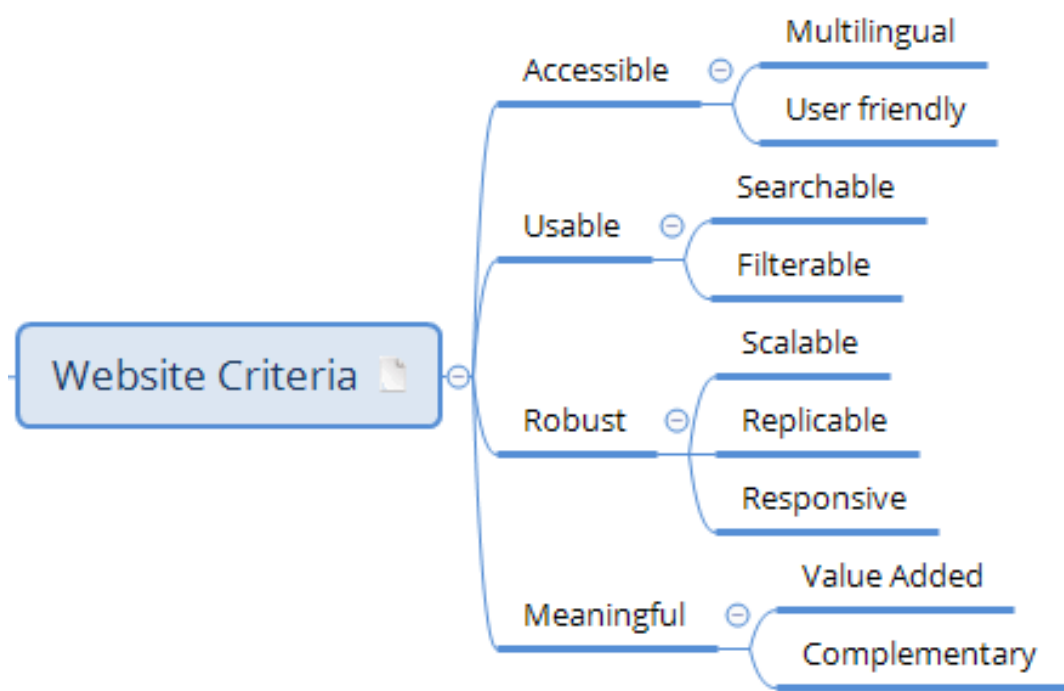
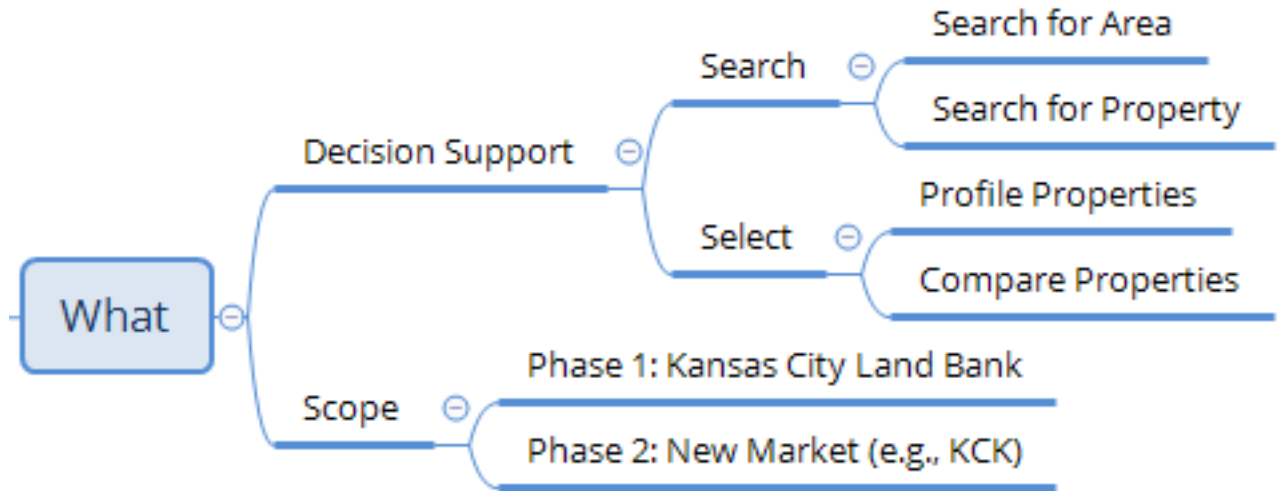

## Customers/Users

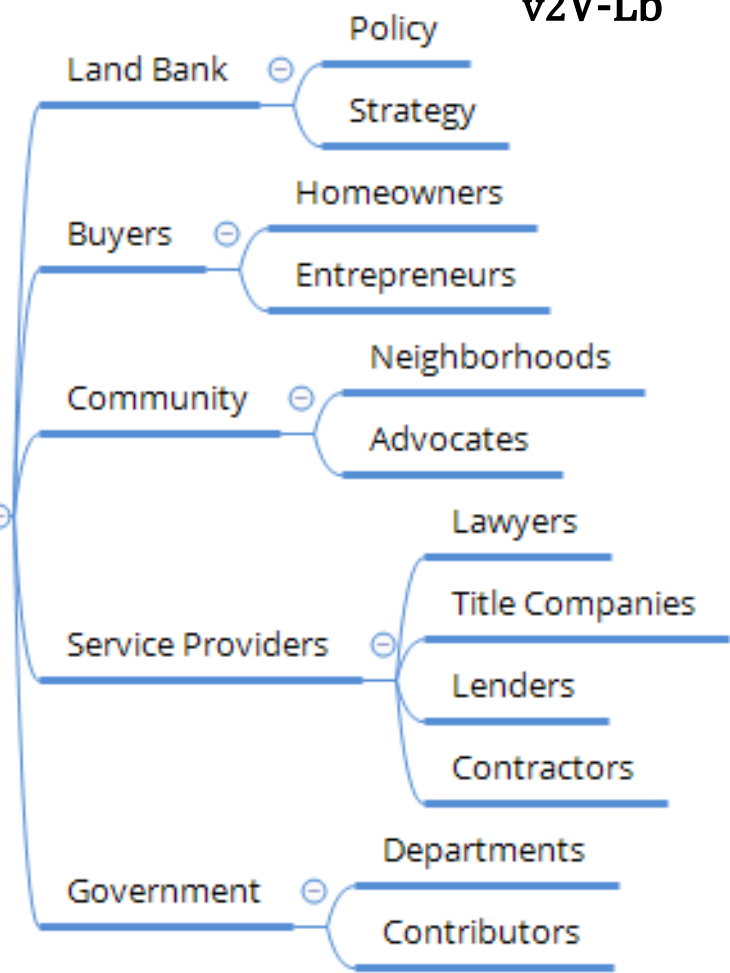

**Development Team:**  
**Andrei Adulescu**  
**Jim DeLisle**  
**Ron House**  
**Brent Never**

# Applied Theory & Behavioral Approach

## Neighborhood Life Cycles

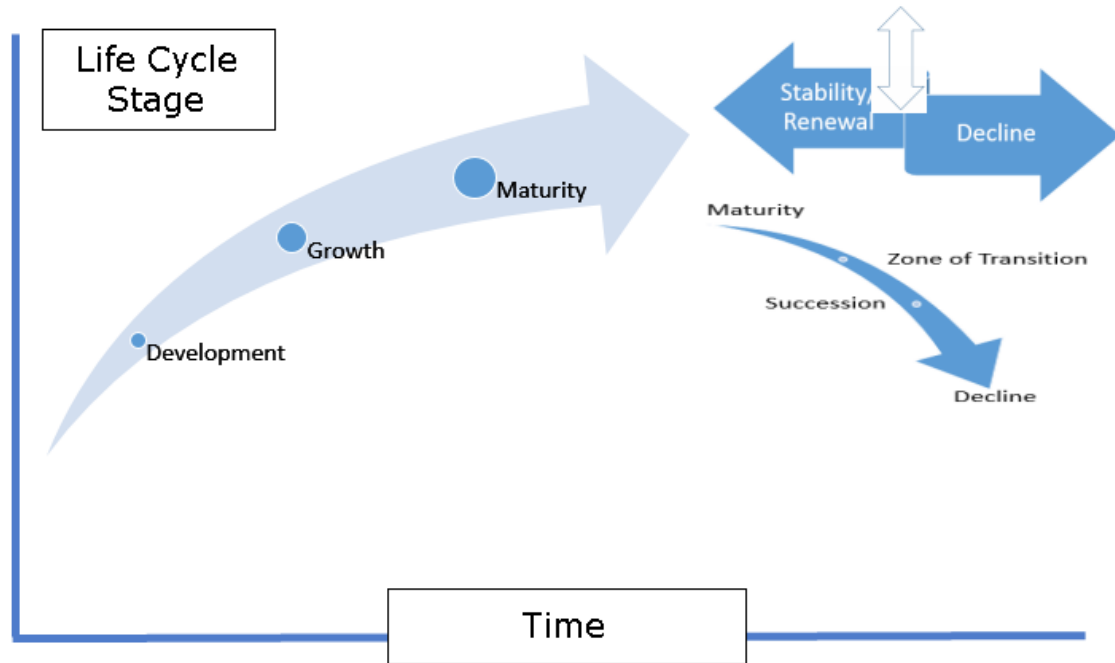

**Behavioral: What variables matter?**

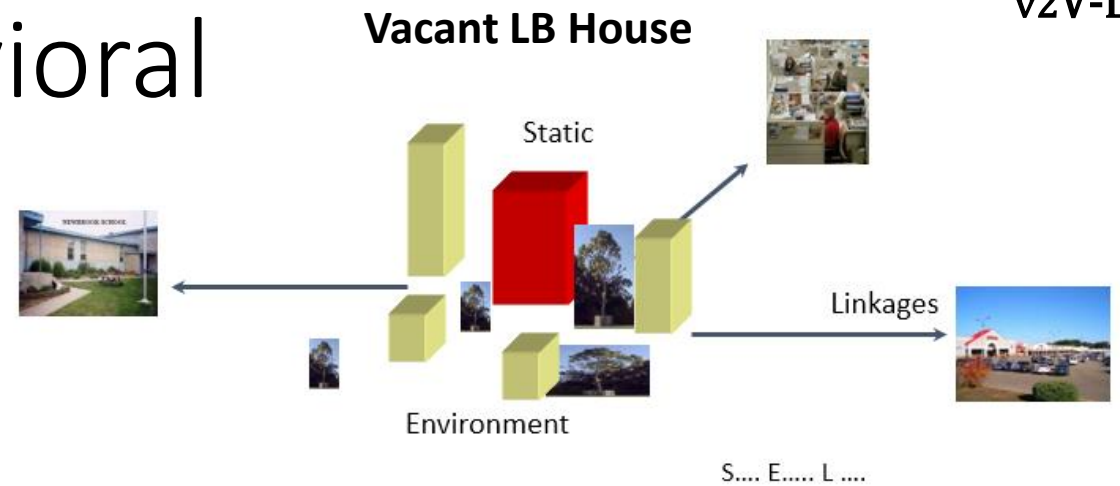

## Blighted Neighborhoods

### Neighborhood Life Cycle Stage

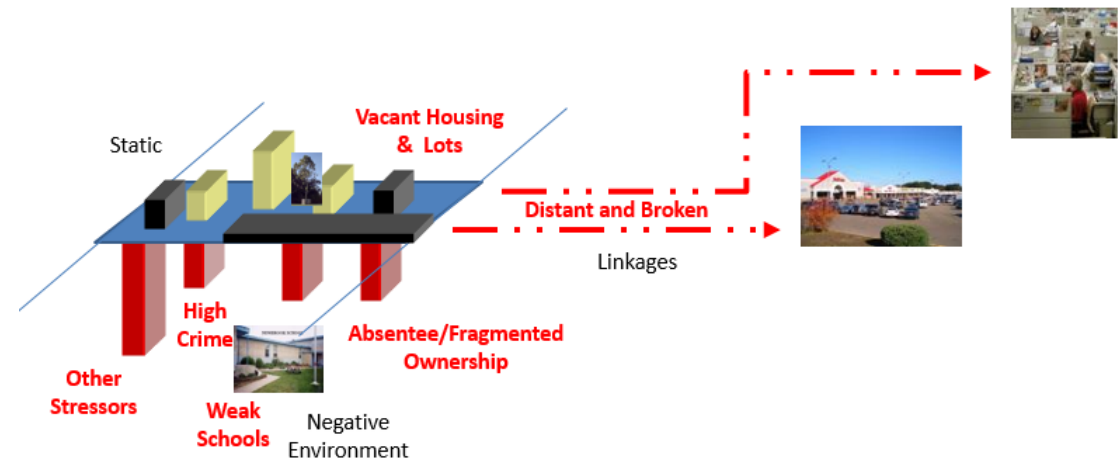

# Issue: Sometimes, what you seek ain't what you get..v2V-Lb

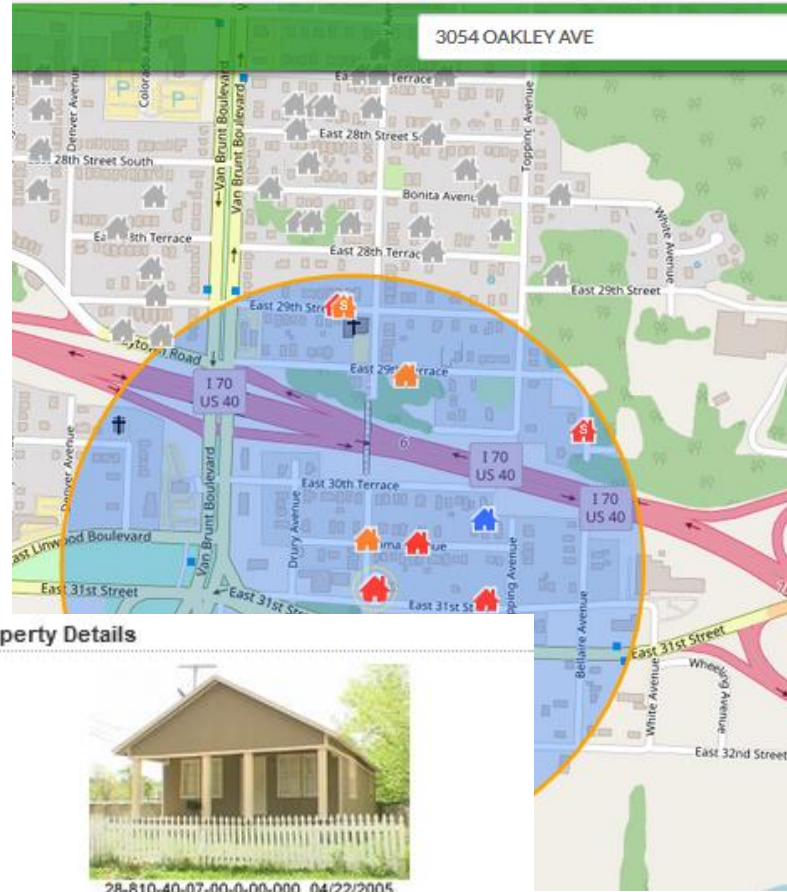
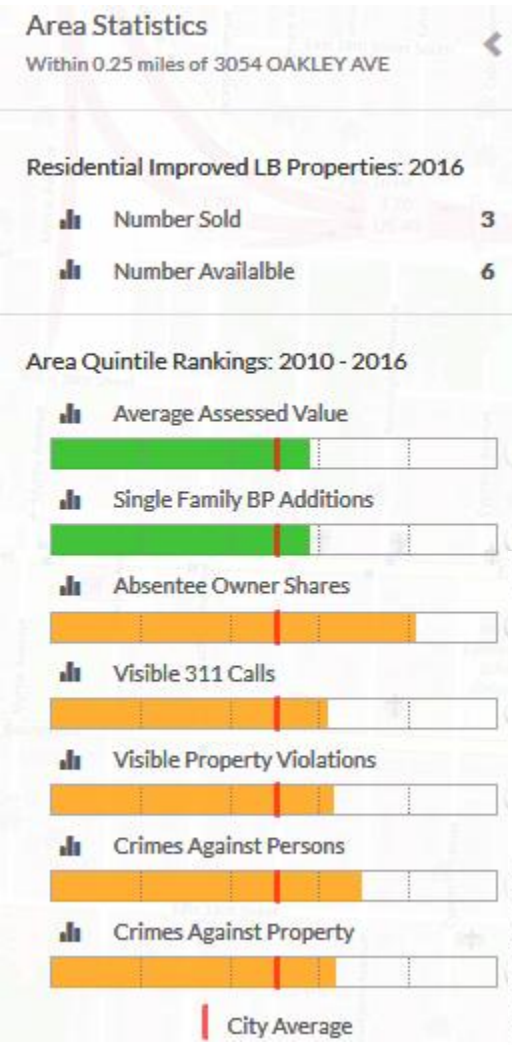

**Address**  
3054 OAKLEY AVE

**Zip Code**  
64128

**Neighborhood**  
South Blue Valley

**Link to County Data**  
[28-810-40-07-00-0-00-000](#)

**Sold/Unsold**  
Unsold

**Year Sold**  
-

**Property Type**  
Residential

**Condition**  
Distressed

**Market Value**  
\$28,670

**Sqft**  
7,380

**Year Acquired**  
2016

[Kansas City Parcel Viewer](#)  
[KCMO Land Bank](#)

**3054 OAKLEY AVE**  
KANSAS CITY, MO 64128  
\$17,762.22

**Listing Details**

**Parcel Number:** JA28810400  
**Neighborhood:** South Blue Valley  
**Market Value:** \$0.00  
**Listing Comments:** Demolition pending, structure not available for purchase. Please call our office at 816-513-9020 for information about the vacant lot that will remain





## Data Development: ID and Capture

- Data Identification: Neighborhood Variables
  - Property Violations
  - 311 Calls: Resident Complaints
  - Crime Rates
  - Land Bank Properties: Sold/Unsold
  - Building Permits
- Data Capture
  - KC MO Open Data Portal
  - Jackson County Assessor Building Permits

The screenshot shows the OpenData KC website interface. The browser address bar displays the URL: [https://data.kcmo.org/browse?q=311 Calls&sortBy=relevance](https://data.kcmo.org/browse?q=311%20Calls&sortBy=relevance). The page header includes the OpenData KC logo and navigation tabs for 'Most Visited', 'JRD\_Research', 'Investing', 'Spotify Web Player', 'RE Education', 'Move\_KC', 'Demographics', 'Affordable', 'Economics', and 'Open Data'. A search bar contains the text '311 Calls'. Below the search bar, a filter menu for 'Authority' is visible, with options for 'Official' and 'Community'. The search results section shows '179 Results' and a prominent result for '311 Call Center Service Requests' with 311 items. A description below the result states: 'This data set contains call record data from the 311 call center in Kansas City, MO. 1 under the name "KCMOPS311". This name was changed to make the dataset name'.

### Data Development

- Data Identification
- Data Capture
- Data Scrubbing
- Data Blending

Updated

**October 4, 2017**

Data Last Updated    Metadata Last Updated  
October 4, 2017      October 4, 2017

Date Created  
June 7, 2013

Views      Downloads  
**7,930**      **56K**

Data Provided by      Dataset  
KCMO Information Technology      Owner  
People Soft CRM cases      K. Mesa

Contact Dataset Owner

# Raw Data and Processing

Join by BLOCKGRP				Number of Incidents
Alteryx	JOIN_BLOCKGRP_REDVARs_V10.yxmd	BLOCKGRPS	Fields	
Input File	CRIME_BY_BLOCKGRP_OUTPUT_v1.yxdb	366	35	684,135
Input File	UNIQUE_CRIME_BY_BLOCKGRP_OUTPUT_v1.yxdb	366	35	684,135
Input File	ABS_LANDUSE_GROUP_BY_BLOCKGRP_OUTPUT_V25.yxdb	348	178	133,051
Input File	PV_BY_BLOCKGRP_OUTPUT_v1.yxdb	335	45	454,244
Input File	311_CALLS_BY_BLOCKGRP_OUTPUT_v1.yxdb	345	45	540,011
Input File	BP_2010_2016_BLOCKGRP_v1.yxdb	349	31	62,635
Input File	LBSOLD_UN SOLD_BY_BLOCKGRP_OUTPUT_v2.yxdb	225	71	5,596
Input File	LBSOLD_VERIFIED_BY_TRACT	175	62	1,554
Output	JOIN_BLOCKGRP_ALLVARs_noBPLB_v1_OUTPUT_v1.yxdb	372	502	2,563,807

# Data Development: Crime

- Identify Data
- Compile by Year
- Join to Time Series
- Code to IBRS
- Sum to IBRS
- Map to Geographies
- Map to Properties

Crime	2009-2016		
All		193	332867
Property		186	86458
Person		188	205260
Joined All + Person + Property		193	332867

IBRS	IBRS_GROUP	IBRS_DESC	CRIME_GRP	AGAINST	IBRS_DESC	NUMBER
100	Other	Kidnapping/Abduction	OTHER	Person	Kidnapping/Abduction	60
120	Robbery	Robbery	ROB_BURG	Property	Robbery	31500
200	Other	Arson	ARSON	Property	Arson	3212
210	Theft	Extortion/Blackmail	THEFT	Property	Extortion/Blackmail	18
220	Burglary	Burglary	ROB_BURG	Property	Burglary/Breaking & Entering	77410
240	MV_Theft	Motor Vehicle Theft	MV_THEFT	Property	Motor Vehicle Theft	78060
250	Theft	Counterfeiting/Forgery	THEFT	Property	Counterfeiting/Forgery	5555
270	Theft	Embezzlement	THEFT	Property	Embezzlement	1646
280	Theft	Stolen Property Offenses	THEFT	Property	Stolen Property Offenses	2037
290	Vandalism	Vandalism	VANDALISM	Property	Destruction/Damage/Vandalism	56060
370	Sex	Pornography/Obscene Mater	SEX	Society	Pornography/Obscene Material	110
510	Sex	Bribery	SEX	Property	Bribery	
520	Gun_Homicide	Weapon Law Violations	GUN_HOMICIDE	Society	Weapon Law Violations	5768
08A	Gun_Homicide	Homicide Offenses	GUN_HOMICIDE	Person	Murder & Negligent Manslaughter	1899
09B	Gun_Homicide	Homicide Offenses	GUN_HOMICIDE	Person	Negligent Manslaughter	5
09C	Gun_Homicide	Homicide Offenses	GUN_HOMICIDE	Person	Justifiable Homicide (not a crime)	24
11A	Sex	Sex Offenses	SEX	Person	Rape	2788
11B	Sex	Sex Offenses	SEX	Person	Sodomy	2004
11C	Sex	Sex Offenses	SEX	Person	Sexual Assault With An Object	22
11D	Sex	Sex Offenses	SEX	Person	Fondling	1530
13A	Assault	Assault	ASSAULT	Person	Aggravated Assault	41610
13B	Assault	Assault	ASSAULT	Person	Simple Assault	75280
13C	Assault	Assault	ASSAULT	Person	Intimidation	6820
23A	Larceny	Larceny/Theft Offenses	LARCENY	Property	Pocket-picking	663
23B	Larceny	Larceny/Theft Offenses	LARCENY	Property	Purse-snatching	806
23C	Larceny	Larceny/Theft Offenses	LARCENY	Property	Shoplifting	26517
23D	Larceny	Larceny/Theft Offenses	LARCENY	Property	Theft from Building	27026
23E	Larceny	Larceny/Theft Offenses	LARCENY	Property	Theft from Coin-Operated Machine	285
23F	MV_Theft	Larceny/Theft Offenses	MV_THEFT	Property	Theft from Motor Vehicle	39453
23G	MV_Theft	Larceny/Theft Offenses	MV_THEFT	Property	Theft of Motor Vehicle Parts or Acc	32869
23H	Larceny	Larceny/Theft Offenses	LARCENY	Property	All Other Larceny	25578
26A	Fraud	Fraud Offenses	FRAUD	Property	False Pretenses/Swindle/Confiden	5357
26B	Fraud	Fraud Offenses	FRAUD	Property	Credit Card/Automated Teller	4186
26C	Fraud	Fraud Offenses	FRAUD	Property	Impersonation	4413
26D	Fraud	Fraud Offenses	FRAUD	Property	Welfare Fraud	12
26E	Fraud	Fraud Offenses	FRAUD	Property	Wire Fraud	1273
35A	Drug_Alco	Drug/Narcotics Offenses	DRUG_ALCO	Society	Drug/Narcotic Violations	21625
35B	Drug_Alco	Drug/Narcotics Offenses	DRUG_ALCO	Society	Drug Equipment Violations	7370
36A	Sex	Sex Offenses, Nonforcible	SEX	Person	Incest	7
36B	Sex	Sex Offenses, Nonforcible	SEX	Person	Statutory Rape	419
39A	Other	Gambling Offenses	OTHER	Society	Betting/Wagering	
39B	Other	Gambling Offenses	OTHER	Society	Gambling/Promoting/Assisting Gam	3
39C	Other	Gambling Offenses	OTHER	Society	Gambling Equipment Violations	
39D	Other	Gambling Offenses	OTHER	Society	Sports Tampering	
40A	Sex	Prostitution Offenses	SEX	Society	Prostitution	1222
40B	Sex	Prostitution Offenses	SEX	Society	Assisting or Promoting Prostitution	163
40C	Sex	Prostitution Offenses	SEX	Society	Purchasing Prostitution	
64A	Sex	Human Trafficking	SEX	Person	Human Trafficking - Commercial Sex Acts	
64B	Sex	Human Trafficking	SEX	Person	Human Trafficking, Involuntary Servitude	
90A	Theft	Bad Checks	THEFT	Property	Bad Checks	187
90B	Other	Curfew/Loitering/Vagrancy V	CURFEW_DISORD	Society	Curfew/Loitering/Vagrancy Violatio	398
90C	Other	Disorderly Conduct	CURFEW_DISORD	Society	Disorderly Conduct	9060
90D	Drug_Alco	Driving Under the Influence	DRUG_ALCO	Society	Driving Under the Influence	4075
90E	Drug_Alco	Drunkenness	DRUG_ALCO	Society	Drunkenness	613
90F	Other	Family Offenses, Nonviolent	OTHER	Society	Family Offenses, Nonviolent	3065
90G	Drug_Alco	Liquor Law Violations	DRUG_ALCO	Society	Liquor Law Violations	1070
90H	Other	Peeping Tom	OTHER	Society	Peeping Tom	17
90I	Other	Runaway	OTHER	Society	Runaway	41
90J	Trespass	Trespass of Real Property	TRESPASS	Society	Trespass of Real Property	16025
90Z	Other	All Other Offenses	OTHER	Society	All Other Offenses	56678

v2V-Lb

# 311 Calls: Mapping Table

356 Categories in Raw Data

CALLACCL16	Acceleration 2016 in Total Calls	Total 2016/(Total (2010-2015))		
ANIMAL	Animal Calls	Barking, biting, emergency, injury, stray, dead, rat, wildlife	24	VIS_NOTVIS
CITYSVCS	City Service Calls	Capital projects (parks, public works, water, sewer...)	50	NOTVIS
ENVHLSFTY	Environmental and Safety Calls	Disease, public facilities, lead poisoning	8	NOTVIS
GRAFFITI	Graffiti Calls	City, park, private, streetlight, signs	7	VIS
MOWWEED	Mowing and Weed-related Calls	Mowing, weeds for parks, private, public, ROW	16	VIS
NUISANCE	Nuisance Calls	Noise, all nuisance	2	VIS
PARKMAINT	Park and Park Maintenance Call	Park landscape, maintenance, graffiti	15	VIS_NOTVIS
PERZONING	Zoning Calls	Permits and zoning calls	3	VIS_NOTVIS
PROPERTY	Property Calls	Construction, elevators, parking, maintenance, paint...	10	VIS_NOTVIS
PROPBOARD	Property Boarded Up Calls	Property boarded up	1	VIS
DANGERBLD	Dangerous Buildings Calls	Dangerous buildings	1	VIS
PROPViol	Property Violation Calls	Private property, inspection	3	VIS_NOTVIS
PUBHLSFWKS	Public health, safety & works	Disease, food, noise, air quality, fire, safety	18	VIS_NOTVIS
ROADSLTSGN	Roads, lights & signs	Encroachment, signal damage, outages, signs	57	VIS
SEWWATSTM	Sewer, waste and stormwater	All, cleaning, repair, investigation	17	VIS
SIDEWALK	Sidewalk, curbs & ditches	Disrepair, hazardous, obstructure, snow/ice	10	VIS
TRASH	Trash	Animal, illegal dumping, investigation, cleanup	11	VIS
TRASHBULK	Bulk Trash	Appointments, storm cleanup	32	NOTVIS

# Data Development: Amenities

ALLPTAV	All Property Type Assessed Value	[RESALLV]+[COMALLV]+[AMENALLV]+[OTHALLV]
RESALLSHV	Residential All Share All Assessed Value	[RESALLV]/[ALLPTYPEV]
COMINDALLV	Commercial Industrial All Share All Assessed Value	[COM_INDH]+[COM_INDL]+[COM_INDUT]+[COM_INDWM]
AMENALLSHV	Amenity All Share of All Assessed Value	[AMENALLV]/[ALLPTYPEV]
OTHALLSHV	Other II Share of All Assessed Value	[OTHALLV]/[ALLPTYPEV]
RESMFALLV	Residential Multifamily All Assessed Value	[RES_CONDO]+[RES_MF_CA]+[RES_MF]
RESMFHAV	Residential Multifamily All Share of All Assessed Value	[RESMFALLV]/[ALLPTYPEV]
COMALLSHV	Commercial All Share of All Assessed Value	[COMALLV]/[ALLPTYPEV]
RES1FSHAV	Residential Single Family All Share of All Assessed Value	[RES_1F]/[ALLPTYPEV]
COMOFFSHAV	Commercial Office All Share of All Assessed Value	[COM_OFF]/[ALLPTYPEV]
COMINDSHAV	Commercial Industrial All Share of All Assessed Value	[COMINDALLV]/[ALLPTYPEV]
VACALLSHAV	Vacant Parcel All Share of All Assessed Value	([COM_VAC]+[RES_VAC])/[ALLPTYPEV]
AMEDUCSHAV	Education Amenity All Share of All Assessed Value	[AMEN_ED]/[ALLPTYPEV]
AMCULTSHAV	Cultural Amenity All Share of All Assessed Value	[AMEN_CULT]/[ALLPTYPEV]
AMMEDSHAV	Medical Amenity All Share of All Assessed Value	[AMEN_MED]/[ALLPTYPEV]
AMCHRCSHAV	Church Amenity All Share of All Assessed Value	[AMEN_CHR]/[ALLPTYPEV]
AMOPSSHAV	Open Space Amenity All Share of All Assessed Value	[AMEN_OSP]/[ALLPTYPEV]
RVACSHALLV	Residential Vacant All Share of All Assessed Value	[RES_VAC]/[ALLPTYPEV]
CVACSHALLV	Commercial Vacant All Share of All Assessed Value	[COM_VAC]/[ALLPTYPEV]
RVACSHRESV	Residential Vacant Share of All Residential Assessed Value	[RES_VAC]/[RESALLV]
CVACSHCOMV	Commercial Vacant Share of All Commercial Value	[COM_VAC]/[COMALLV]

# Data Process: Crime Variables

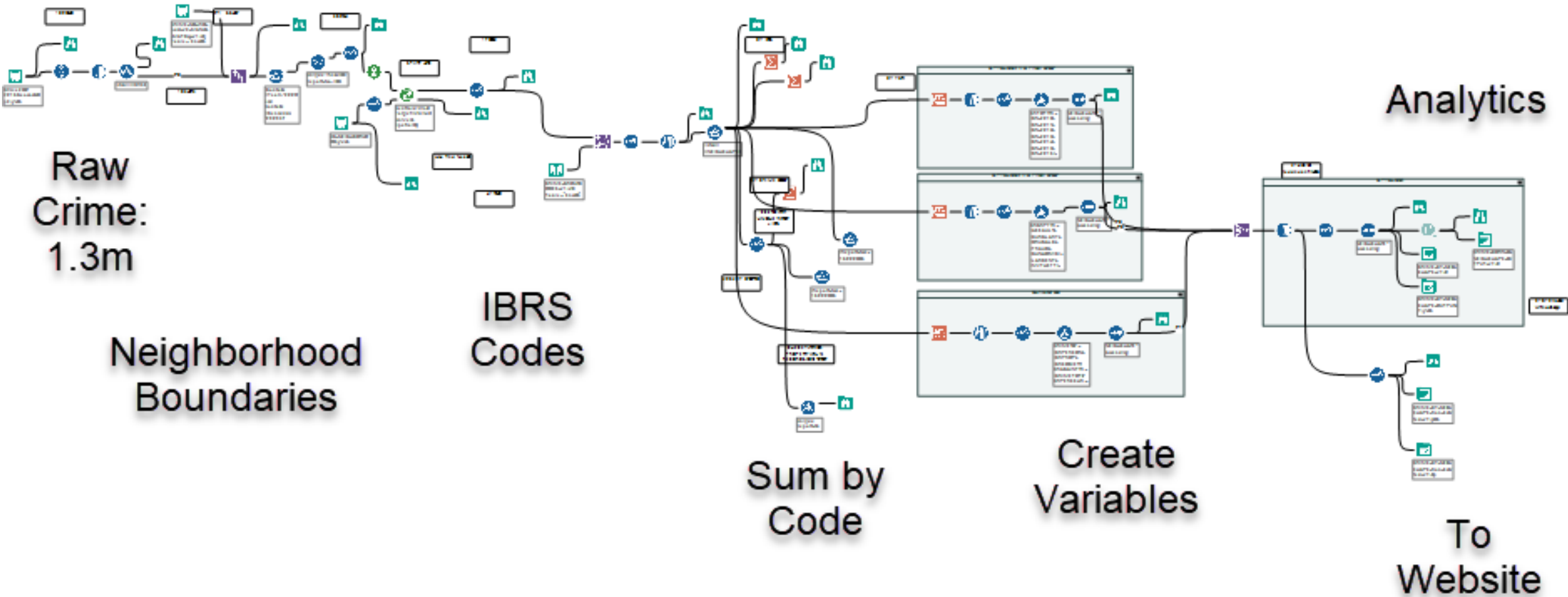

# Geographic Matching

## Census

- Census Tract
- Census Block Group

## Other Geographies

- Zip code
- Neighborhood
- City Block

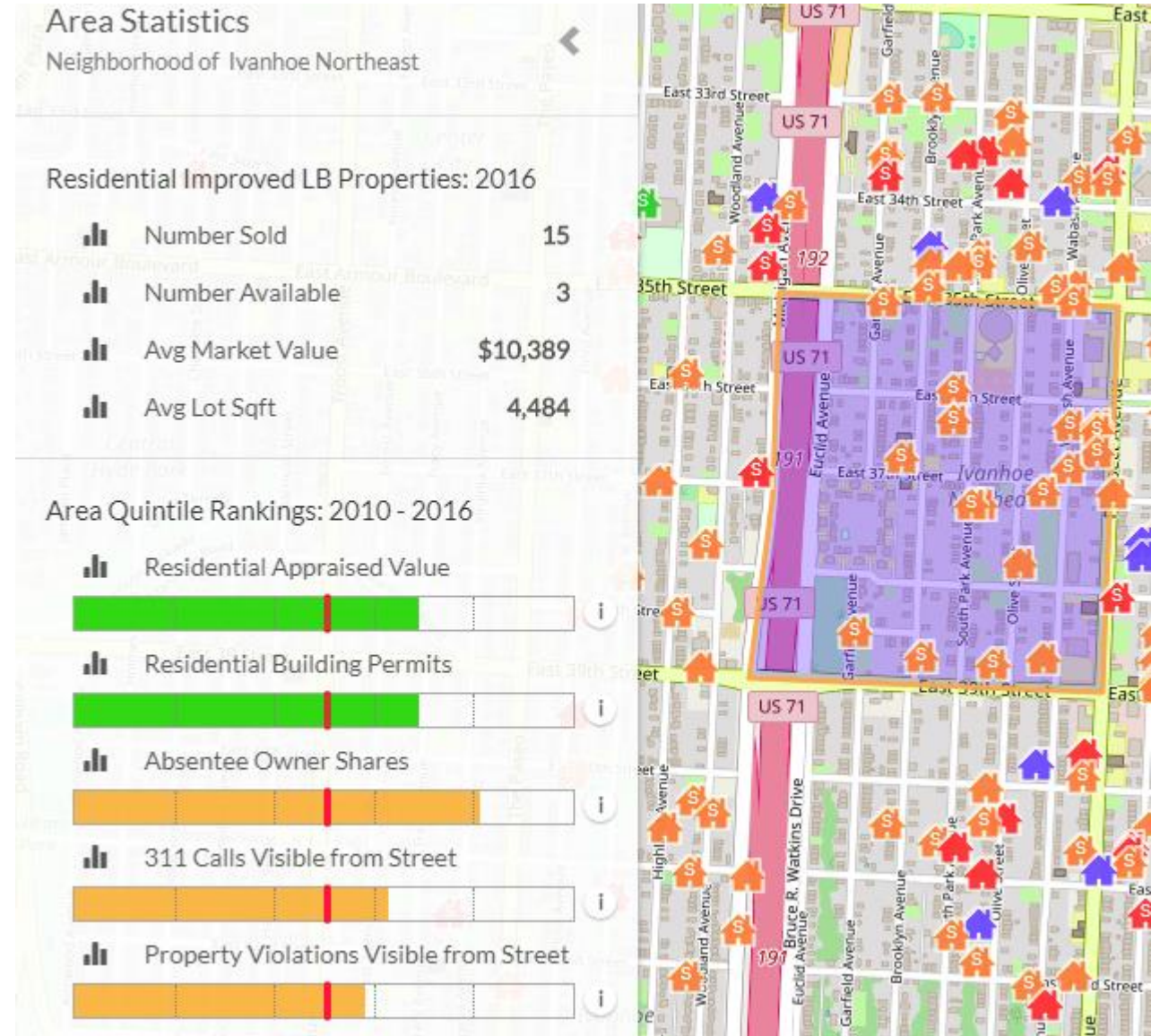

# Data Aggregation: City Block, BlockGRP, Zip, NEIGH, Tract

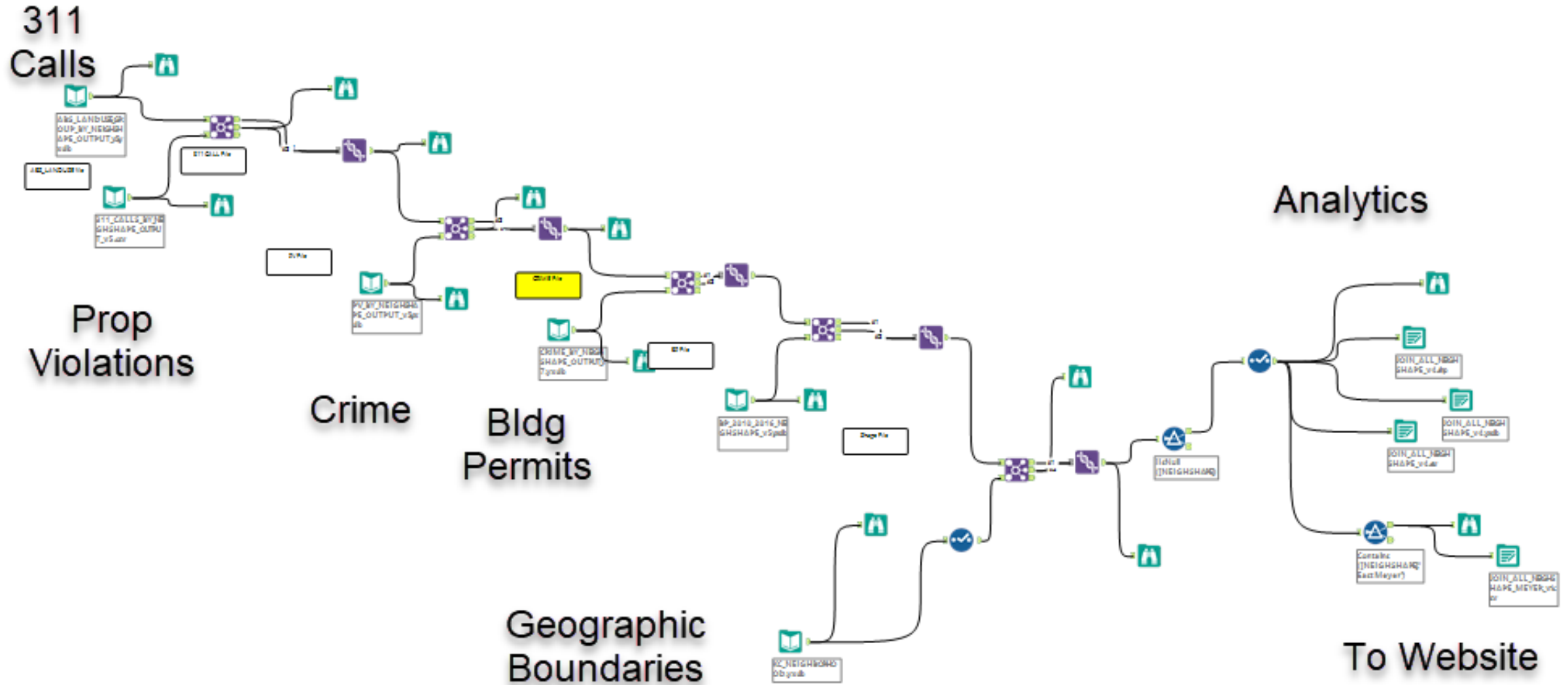



# Interactive Website: [Beta Test](#)

Welcome to the  
Vacant to Vibrant  
Land Bank Website



Enter an address, neighborhood, or Zip Code

Kansas City, MO Only



[Search Land Bank Properties](#)

**Notice:**

Please be advised the data displayed here is for information purposes and may not be accurate in all cases. If you would like to register as a user, we may collect additional data like age, gender, and location.

# Additional Features: Phase 2

## Current Website

- Mobile App GPS-enabled
- Print results
- Compare Properties Side-by-Side
- Customized Search
  - Slider for Variables (e.g., max crime)
  - Select Variables from Drop-down List
- Added Features
  - Comments
  - Tutorials: Video, written
  - Add links/resources
  - Heatmap Layers

## Added Data

- Demographics
- New Variables
- Calculated Variables
- Amenities
- Links

# Predictive Analytics

- DV: Natural log of Single-Residence and Single-Residence-Owner Home Count
- IV:
  - African-American Percent (1.246\*\*\*)
  - Natural log, Hispanic Percent
  - Natural log, Foreign-Born
  - Same Home Rate (1 Year)
- R-Square: .73
- AIC: 197.4

SOLDUNS	Number	NUM311	NUMPV	AVG311	AVGPV	POPAVG	AVGMED	AVGHH	AVGEMP
Unsold	776	8,863	1,934	11.4	2.7	834.7	24326.1	43.8	298.3
Sold	504	5,336	1,272	10.6	2.8	842.0	26034.5	46.4	312.1
Total	1,280	14,199	3,206						

# Issues and Phase 3 Expansion

## Issues

- Maintenance
- Ownership
- Hosting
- Privacy & Security
- Liability: Risk Management

## Expansion

- New Markets (KC-K, St. Louis ???)
- Predictive Analytics: Sold/Unsold
- Policy Implications: Targeting Investments, Incentives

Area Stat Presentation Options



## User Tracking

```
v2v_auth on postgres@AAGIS
1  SELECT * FROM users
2
3  SELECT COUNT(U.email), U.email -- , US.search_text, US.created_date
4  FROM user_searches US
5  LEFT OUTER JOIN users U ON US.user_id = U.id
6  GROUP BY U.email
7  -- ORDER BY created_date DESC
8
9
10
11
12
```

	count	email
1	1	kgirosky@gmail.com
2	74	aradules@gmail.com
3	17	neverb@umkc.edu
4	21	ronh.allabouts@gmail.com
5	108	delislej@umkc.edu